

OPERATION AND MAINTENANCE MODEL 816 AND 816V TOGGLE VALVES

The Model 816 toggle valve is an open or shut (2 way) valve for air or gas lines up to 6000 PSI. The 816V is a 3 way valve that vents downstream pressure when the toggle is released. In the normal or relaxed position the valve is shut and the lever extends straight out. When the lever is tipped in any direction the valve opens. A variety of levers can be connected to the 1/4"-20 thread. For example, using an eye bolt as shown, the valve could be operated by a lanyard. In many cases the valve eliminates the need for snap action switches, solenoids, and other complicated devices to open or shut a line based on mechanical action. One typical application is to open a cylinder charging line only when a protective door is shut. Here the door would push against the toggle to open the valve. A maximum of 30 inch pounds is required to actuate the valve at rated pressure. For example, a six inch lever would require five pounds to operate. A one inch thread section is provided on both ends permitting a variety of ways to mount the valve.

TECHNICAL SPECIFICATIONS

Maximum pressure, inlet	6000 PSI
differential	6000 PSI
outlet	6000 PSI
Ports, inlet	1/4" MNPT
outlet	1/4" FMPT
Flow coefficient (Cv)	.05 (.07" orifice)
Materials, body	anodized aluminum
internals	brass & stainless
seals	Viton(TM) & KEL-F
Mod 816 lever actuating force	30 in-lbs at 6000

INSTALLATION

Use pipe thread sealant teflon tape on inlet and outlet threads. Do not over torque. Moderate torque applied with a 6 or 8 inch wrench is ample. Use ample teflon tape - 3 or 4 turns not 1 or 2 turns on pipe threads. The one inch thread at the top or bottom of the valve can be used to mount the valve through a one inch hole in a panel or mounting

plate provided by the user. The actuating lever for the 816 can either be the eye bolt provided or any other lever extending in any direction as required by the application. The lever is mounted to the toggle (item 6 on the drawing) using the 1/4"-20 thread provided. THE CUSTOMER SHOULD PROVIDE A STOP SUCH THAT THE TOGGLE IS NOT FORCED BEYOND IT'S FULL OPEN POSITION. The valve is NOT shipped oxygen clean and should NOT be used for oxygen service as provided. Consult the factory for details on oxygen service.

MAINTENANCE & REPAIR

CAUTION As with any regulator or valve, particulates or moisture can plug or freeze the internal filter or valve seat. This can occur when up-stream dryers are not changed or remain unused for long periods allowing corrosion materials to accumulate. In critical applications where it is important not to lose flow, a larger particulate filter should be used upstream. Also an orifice such as the Aqua model 796 should be used downstream. This reduces the tendency to freeze when moisture is present. Consult factory for details. The user should establish time intervals for changing the valve cartridge, filter and upstream dryers based on experience and service conditions. Back-up systems should be used in very critical applications since field maintenance is hard to insure. The poppet cartridge 832 is a factory assembled item and should be replaced if required and not disassembled unless absolutely necessary. Spare cartridges are available at a nominal cost and should be kept on hand if rapid repairs are required. Under severe conditions repacking of seal item 12, with Cristo lub per the drawing may periodically be required. IN ALL CASES THE UNIT CAN BE RETURNED TO THE FACTORY OR DEALER FOR REPAIR UNDER WARRANTY OR AT A NOMINAL CHARGE. Maintenance or repairs can be done by qualified personnel in a clean environment by following the drawings and parts lists herein. If the stem (item 4) tip becomes deformed from severe use it can be removed from the body by lightly filing off the enlarged section.

AQUA ENVIRONMENT INC.

3100 Kerner Blvd. Unit N, San Rafael, CA 94901 (415) 453 8157

PARTS LIST

ITEM	QTY	PART NO.	DESCRIPTION
1	1	832	poppet cartridge assy
2	1	811	body
3	1	812	cap
4	1	815	stem (816 only)
	1	1525-1	stem, vented (816V only)
5	1	852	toggle cap
6	1	814	toggle
7	1	816-7	1/4 x 20 x 4" eye bolt st
8	1	816-8	1/4 x 20 nut
9	1	816-9	1" x 14, jam nut, plt stl
10	1	816-10	2-018 viton, 90 duro seal
11	1	816-11	2-014 viton, 90 duro seal
12	1	816-12	2-006 viton, 90 duro seal
13	1	816-13	spring C0300 038 0690S (816 only)
14		delete	
15		delete	
16	1	816-16	REPAIR KIT - includes items 1,4,10,11,12,13
	1	816-16V	REPAIR KIT - includes items 1,4,10,11,12,17,18
17	1	726-1	vent seat (816V only)
18	1	816-18	2-009 viton 90 seal (816V only)
19	1	1638	guide

NOTES

1. Use Cristo lub MCG 121 or 11 or equivalent grease on O rings and seals . Fully pack 12, 14, & 15 with Cristo lub MCG 121 or 11 or equivalent.
2. Use Slick 50 grease between (5) and (6) and between (3) and (4).
3. Insure lever action does not put excessive force on piping connections
4. Technical bulletin - 818
5. Tighten cap (3) to body (2) and toggle cap (5) to cap (2) with 180 to 300 inch-pounds of torque.

ASSEMBLY 832 Poppet cartridge

ITEM	QTY	PART NO.	DESCRIPTION
1	1	808	retainer nut
2	1	806	poppet housing
3	1	809	sleeve
4	1	807	seat
5	1	741	poppet
6	1	871-6	2-014 O ring
7	1	871-7	2-009 O ring
8	1	871-8	spring
9	1	871-9	filter

NOTES

1. It is recommended that replacement cartridges are stocked for in-field repairs and defective cartridges returned to the factory for service. In an emergency the cartridge can be serviced by following the above drawing and parts list. Extreme cleanliness is required.

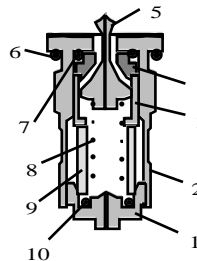
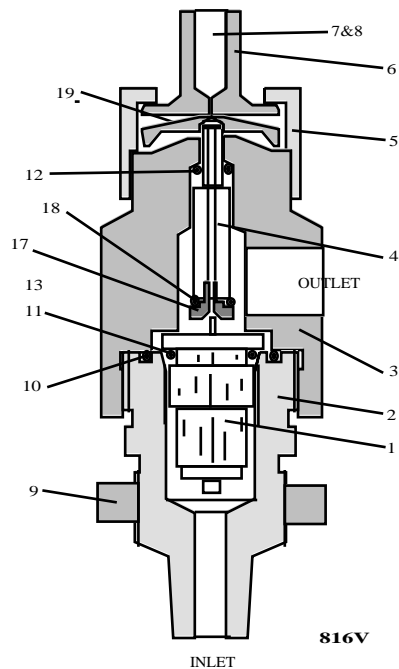
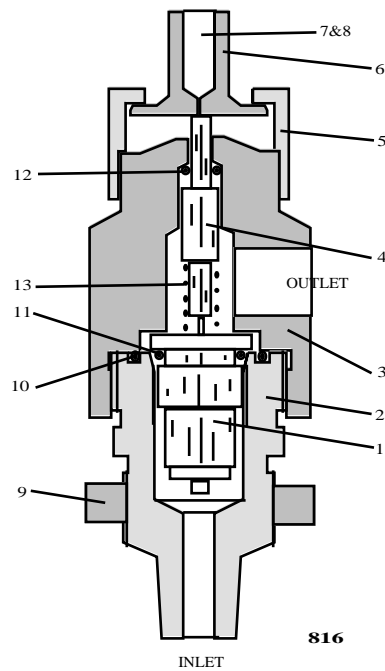

NOTE TO USERS OF 816V VALVES

816V toddle valves shipped prior to 12/18/06 used a spacer (item 19 in the O&M sheet drawing). This spacer has been replaced by a guide p/n 1638 - item 19 in the current O&M sheet. This guide greatly improves the life of the valve by preventing pounding out of the stem in harsh use.

It is recommended, though not essential, the guide 1638 be installed in place of the spacer in valves you may have. Contact Aqua Environment for no charge replacement guides. Install per O&M sheet drw 0819&V revision 061215 attached.

REVISIONS

061215 added item 19 guide 1638 eliminated item 19 spacer
080723 Added note 5 regarding torque spec.